

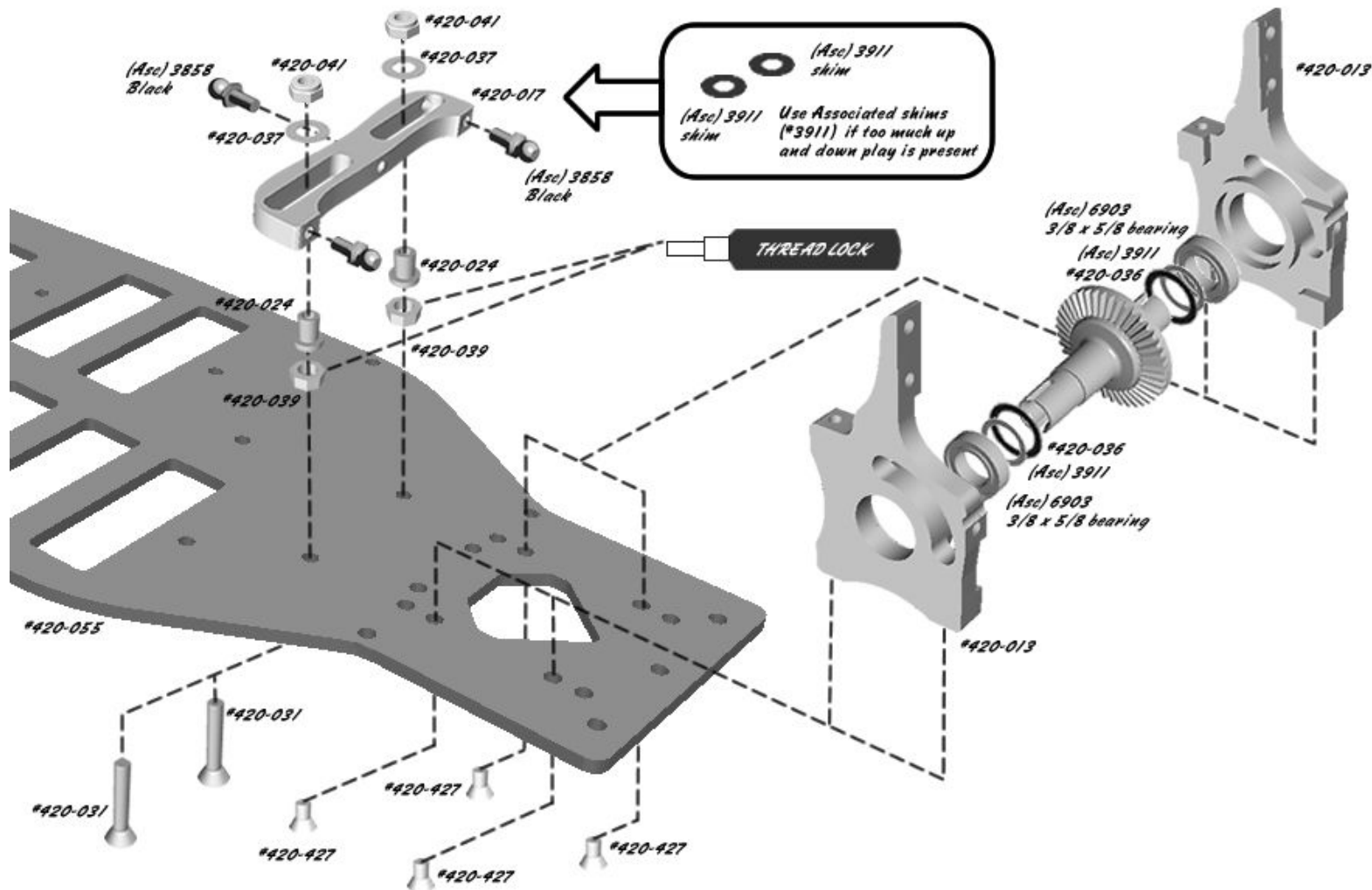

1) Assemble the steering rack (#420-017) using two 3mm x 20mm flat head stainless screws (#420-031), two 3mm nuts (#420-039), two steering bushings (#420-024), two 3mm washers (#420-037), and two 3mm lock nuts (#420-041). You will want to tighten the lock nuts all the way. Use the existing black ball ends from your TC3 or TC4 (#3858) and attach to the steering rack. **NOTE:** If the rack is binding make sure the two 3mm x 20mm flat head screws are not off center; you can use Assoc (#3911) black shims to take any up and down play out.

2) Assemble the front differential housings (#420-013) as shown. You will want to start with one stock Associated diff shim (#3911) and one Diggity Designs diff shim (#420-036) on both sides of the differential. You will make the proper adjustments later if needed. Using four 4-40 x 1/4 flat head stainless screws (#420-427) secure the left and right side differential housings. **DO NOT FULLY TIGHTEN**

Step 1



U
S
E
S
U
E
S
0
1
2
3
4
5
6
7
8
9
X
L
R
8

1) Assemble the rear differential housings (#420-013) as shown. You will want to start with one stock Associated diff shim (#3911) and one Diggity Designs diff shim (#420-036) on both sides of the differential. You will make the proper adjustments later if needed. Using four 4-40 x 1/4 flat head stainless screws (#420-427) secure the left and right side differential housings. **DO NOT FULLY TIGHTEN**.

2) Attach the motor mount (#420-010) to the chassis using two 4-40 x 1/4 flat head stainless screws (#420-427) **DO NOT FULLY TIGHTEN**. Attach the aluminum antenna mount (#420-50) to the chassis using one 4-40 x 1/4 flat head stainless screw (#420-427). There are four mounting holes for the antenna mount depending on radio equipment location.

Step 2

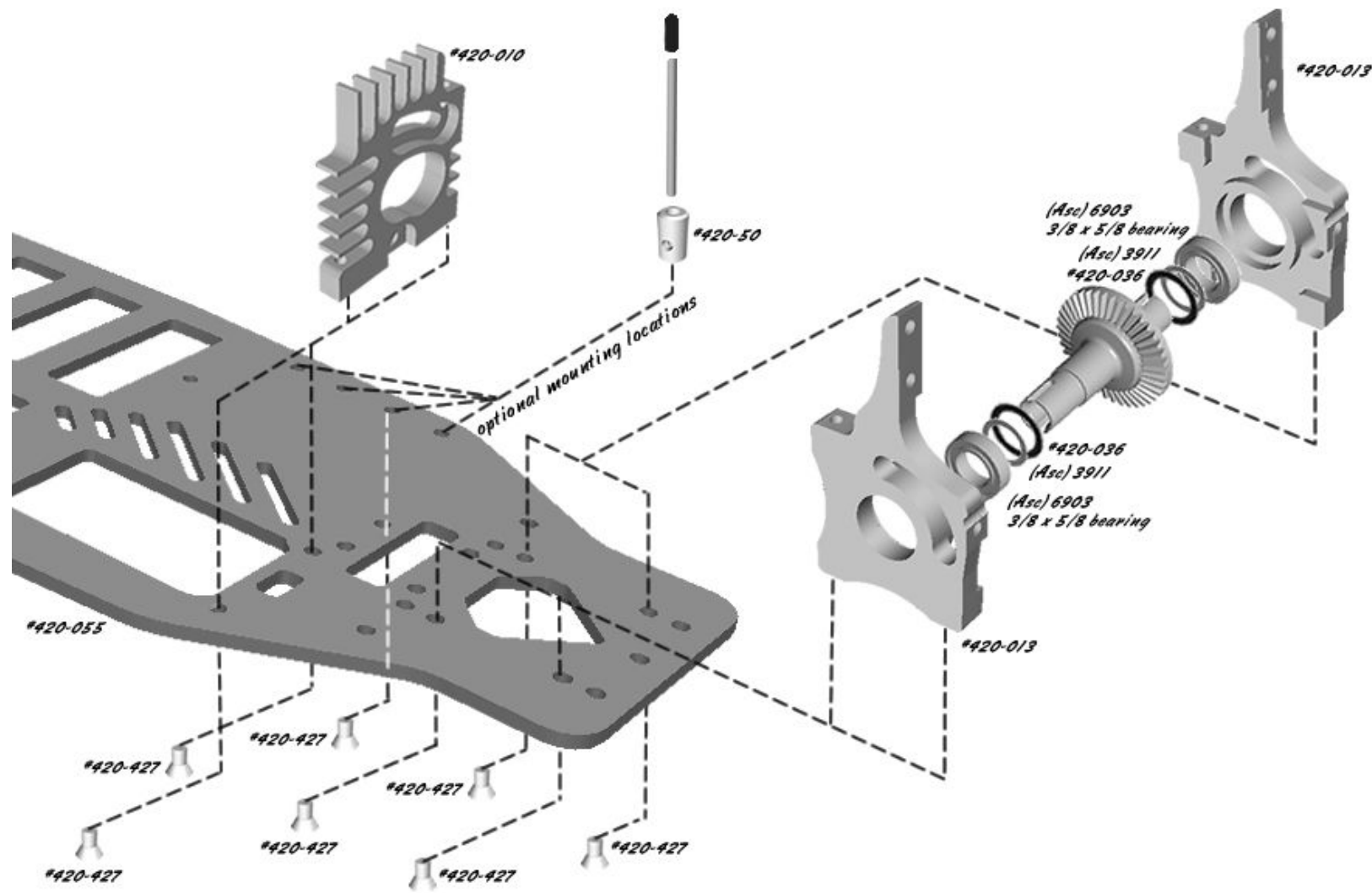

U
S
E
S
E
R
S
M
A
N
U
A
L
X
8

1) Attach the front inner pin blocks (#420-019) using four 4-40 x 1/4 flat head stainless screws (#420-427) to secure them to the chassis **DO NOT FULLY TIGHTEN**. NOTE: You will use two 3mm x 8mm flat head stainless screws (#420-030) to attach the servo mounts.

2) Slide the stock Associated hinge pins (#3866) through the aluminum front arms (#420-011). You will use one brass swivel bushing (#420-026) and one brass washer (#420-062) on each end of the hinge pin as shown. Make sure the brass swivel bushings (#420-026) are on correctly shown in the box below NOTE: you might need to press the bushings on using a light hammer. Slide the front arms (#420-011) into the inner hinge pin blocks (#420-019) first and then finish the assembly by sliding the 0 degree pin block (#420-020) onto the other end of the hinge pins and secure to the chassis using two 4-40 x 1/4 flat head stainless screws (#420-427). **DO NOT FULLY TIGHTEN**

Step 3

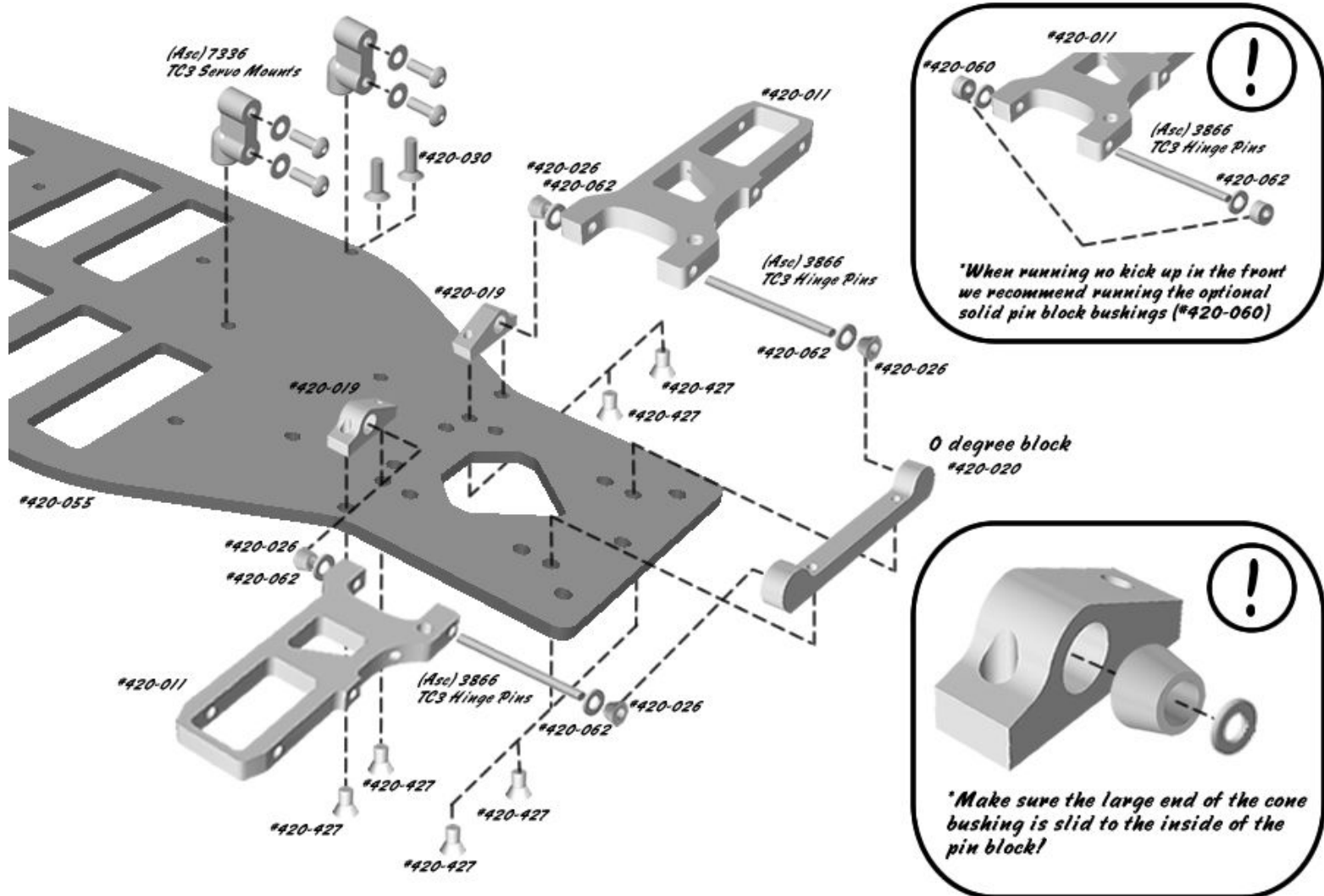

U
S
C
A
R
S
X
L
R
8

1) Attach the rear inner pin blocks (#420-019) using four 4-40 x 1/4 flat head stainless screws (#420-427) to secure them to the chassis DO NOT FULLY TIGHTEN.

2) Slide the stock Associated hinge pins (#3866) through the aluminum rear arms (#420-012). You will use one brass swivel bushing (#420-026) and one brass washer (#420-062) on each end of the hinge pin as shown. Make sure the brass swivel bushings (#420-026) are on correctly shown in the box below NOTE: you might need to press the bushings on using a light hammer. Slide the rear arms (#420-012) into the inner hinge pin blocks (#420-019) first and then finish the assembly by sliding the 1 or 2 degree pin block (#420-021 or #420-022) onto the other end of the hinge pins and secure to the chassis using two 4-40 x 1/4 flat head stainless screws (#420-427). DO NOT FULLY TIGHTEN

Step 4

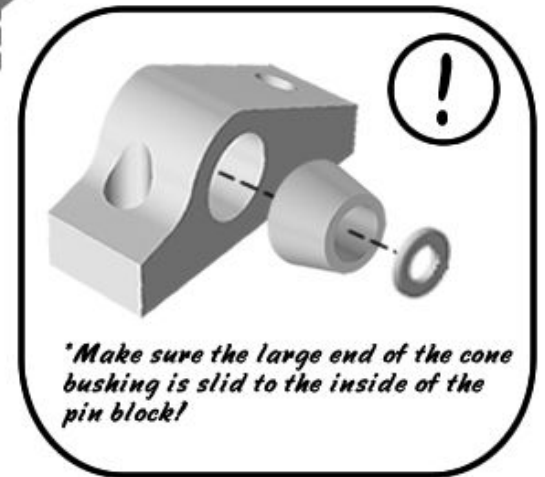
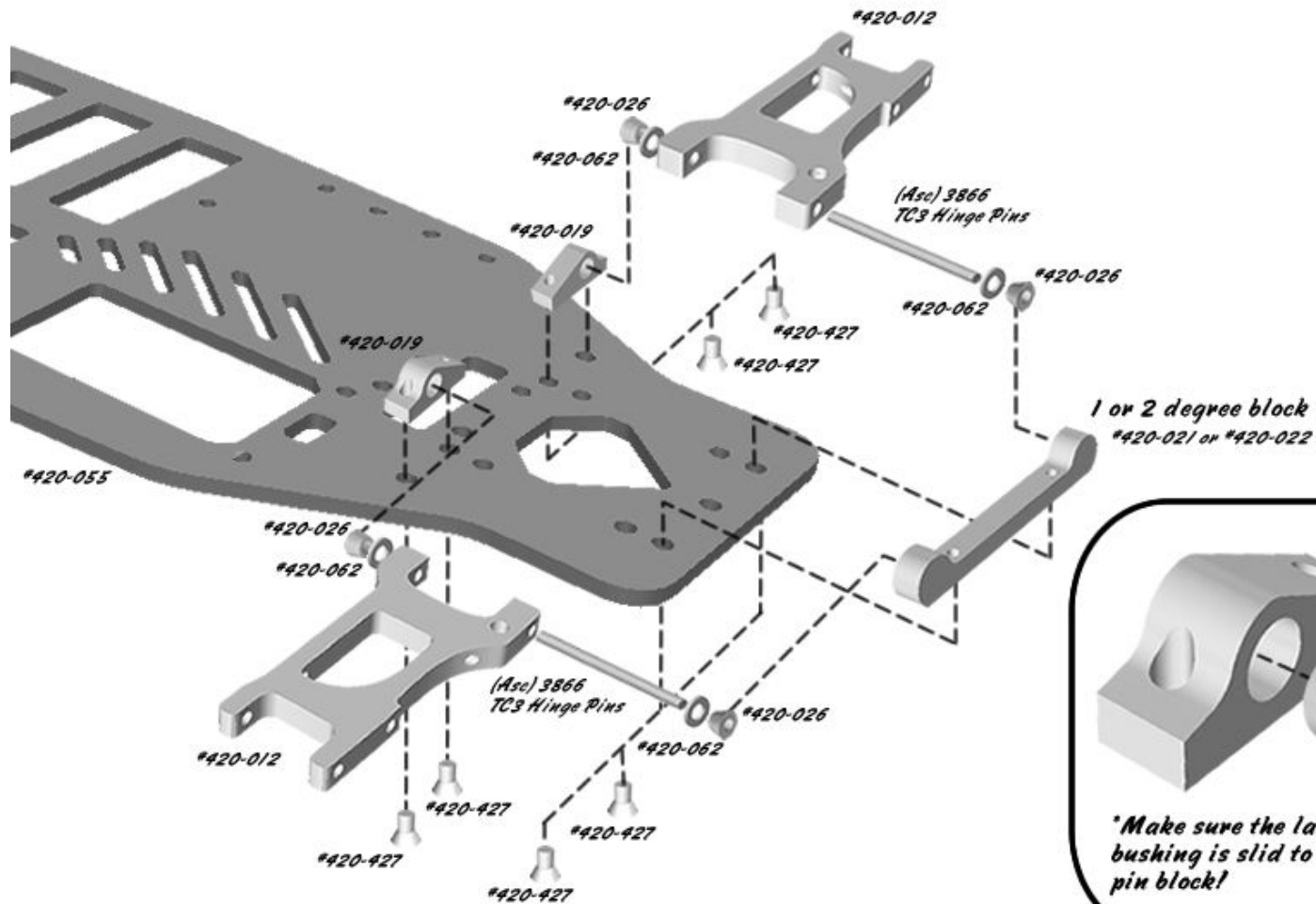



1) Slide the aluminum front/rear shaft support (#420-014) onto the drive shaft (#420-016) followed by one Associated 3/16 x 3/8 bearing (#6906), two Associated shims (#3911) note: the two shims are a starting point and you can adjust later if needed by taking away or adding shims. Slide the Associated pin (#3919) through the shaft hole. Finish sliding the Associated drive pinion (#3914) onto the drive shaft and secure with one 4-40 x 3/16 button head stainless screw (#420-430). Use LIGHT thread lock.

2) Attach the 3mm carbon fibre top plate (#420-050) to the aluminum front/rear shaft support (#420-014) using two 4-40 x 1/4 flat head stainless screws (#420-427). NOTE: you will have to finish the assembly of the drive shaft in Step 6 before you can secure the top plate to the drive shaft unit! DO NOT TIGHTEN TILL LATER

Step 5

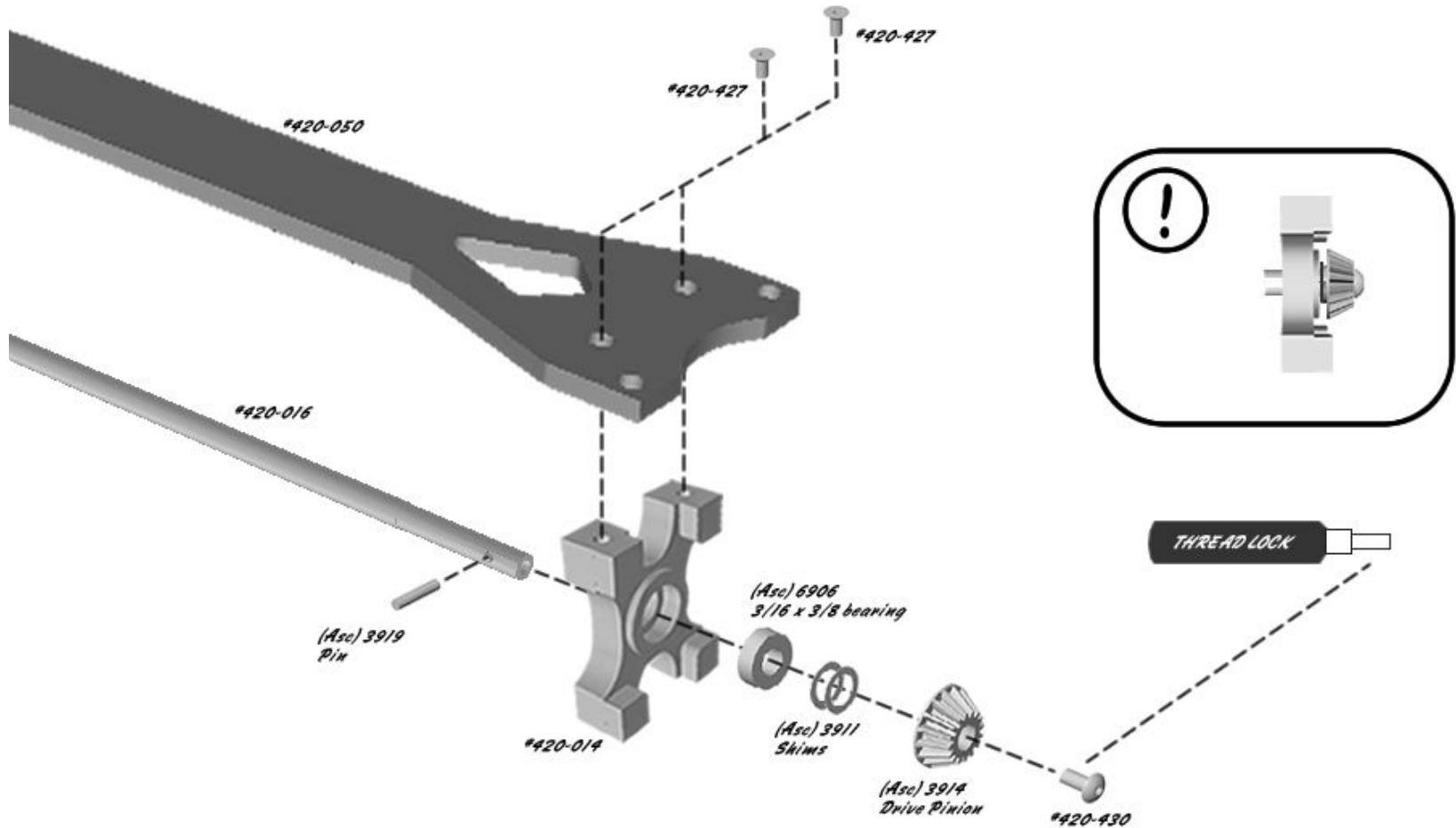

U
S
C
S
U
E
S
0
1
2
3
4
5
6
7
8
9
X
Y
Z

Step 6

1) Slide the aluminum middle shaft support (#420-015) onto the drive shaft (#420-016) followed by one Associated 3/16 x 3/8 bearing (#6906). Slide the gear adapter (#420-018) and spur gear unit onto the drive shaft past the second small hole, slide the short Diggity Designs pin (#420-061) through the drive shaft hole and push the gear adapter up to the pin and clip using the Associated Large E clip (#3919). Slide the aluminum front/rear shaft support (#420-014) onto the drive shaft (#420-016) followed by one Associated 3/16 x 3/8 bearing (#6906), two Associated shims (#3911) note: the two shims are a starting point and you can adjust later if needed by taking away or adding shims. Slide the Associated pin (#3919) through the first shaft hole. Finish sliding the Associated drive pinion (#3914) onto the drive shaft and secure with one 4-40 x 3/16 button head stainless screw (#420-430). Use LIGHT thread lock.

2) Attach the 3mm carbon fibre top plate (#420-050) to the aluminum front/rear shaft support (#420-014) using two 4-40 x 1/4 flat head stainless screw (#420-427) and to the aluminum middle shaft support (#420-015) using one 4-40 x 1/4 flat head stainless screw (#420-427). DO NOT TIGHTEN TILL LATER

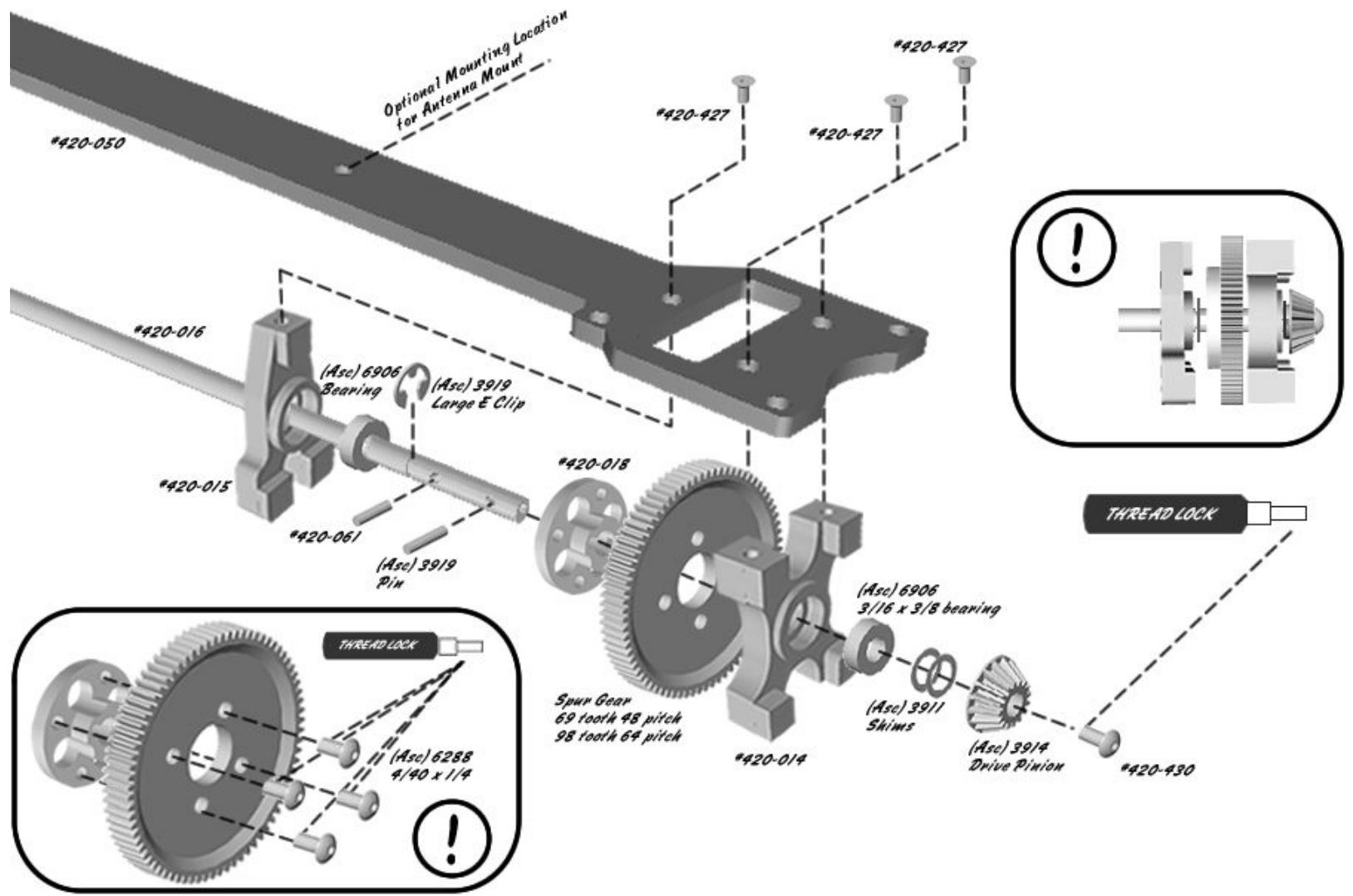



1) Attach the drive shaft assembly to the front/rear right and left differential housings (#420-013) by sliding two 4-40 x 3/8 flat head stainless screws (#420-028) through two aluminum countersunk washers (#420-032) and through the top plate (#420-050) on each end. Slide one 4/40 x 1/4 button head stainless screw (#420-431) through the top plate and secure to the motor mount (#420-010). DO NOT FULLY TIGHTEN

2) Attach the drive shaft assembly to the chassis (#420-055) by using six 4-40 x 1/4 flat head stainless screws (#420-427) and securing them to the aluminum front/rear shaft supports (#420-014) and to the aluminum middle shaft support (#420-015). MAKE SURE YOUR DRIVE LINE DOES NOT BIND AT THIS TIME, IF IT IS TOO LOOSE THEN ADD A SHIM OR TWO WHERE NEEDED AND IF IT IS TOO TIGHT THEN TAKE A SHIM OR TWO AWAY WHERE NEEDED AND THEN REPEAT STEP 7. Most shim adjustments will be in the differential housings, you will want to shim it so that the drive pinion and diff gears are not too loose because you will strip the gears if its not properly adjusted. Once you have a set shimming selection then you will always use the same when rebuilding your car.

Step 7

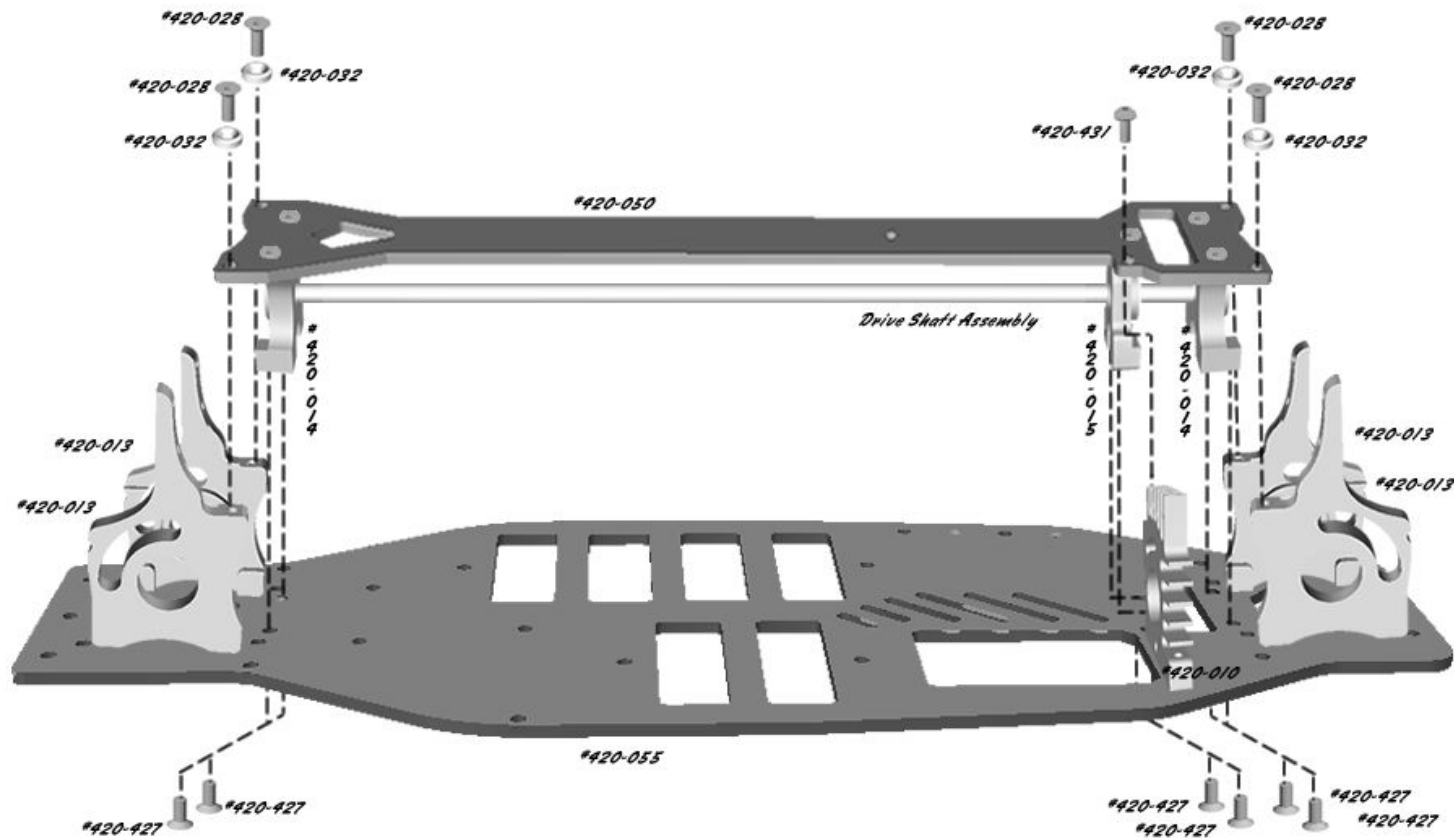



1) Slide one Associated 4-40 x 3/4 pan head screw (#7413) through the front shock tower (#420-053) and secure with an Associated 4-40 mini nut (#7260). Slide one Associated long black ball end (#3858) through the front shock tower and secure with an Associated 4-40 mini lock nut (#4449). Attach the front shock tower (#420-053) using four 4-40 x 1/4 flat head stainless screws (#420-427). DO NOT FULLY TIGHTEN

2) Slide one Associated 4-40 x 3/4 pan head screw (#7413) through the rear shock tower (#420-054) and secure with an Associated 4-40 mini nut (#7260). Slide one Associated long black ball end (#3858) through the rear shock tower and secure with an Associated 4-40 mini lock nut (#4449). Attach the rear shock tower (#420-054) using four 4-40 x 1/4 flat head stainless screws (#420-427). DO NOT FULLY TIGHTEN

Step 8

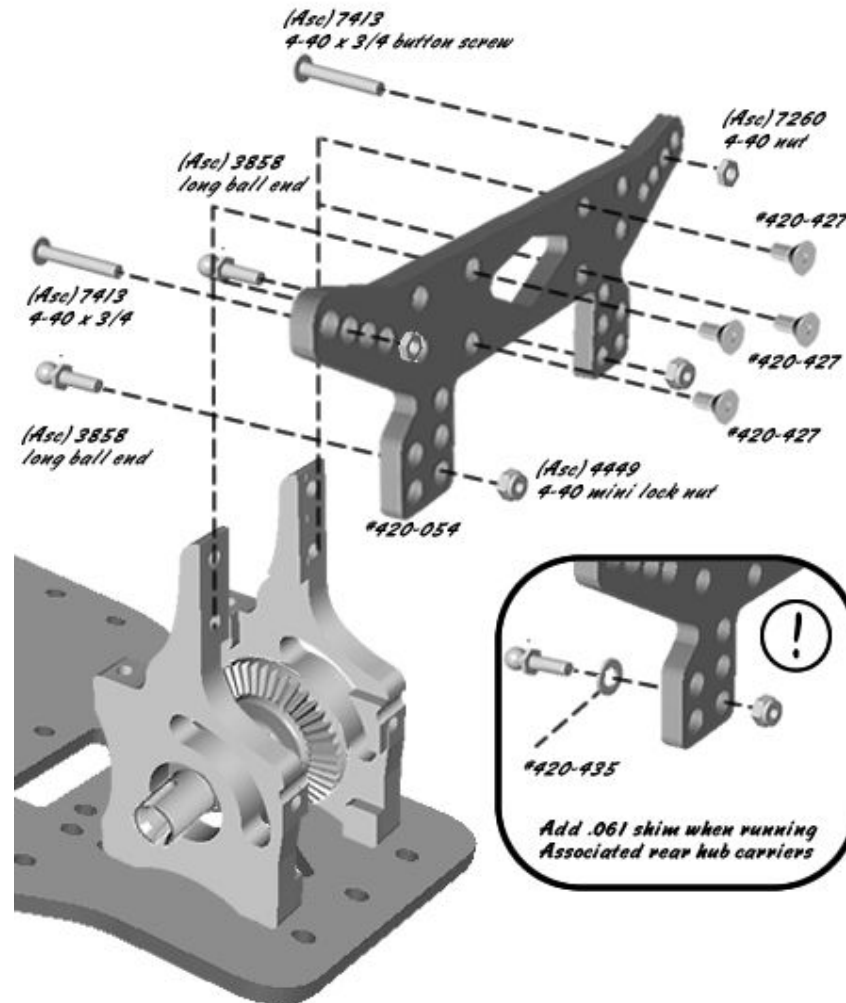
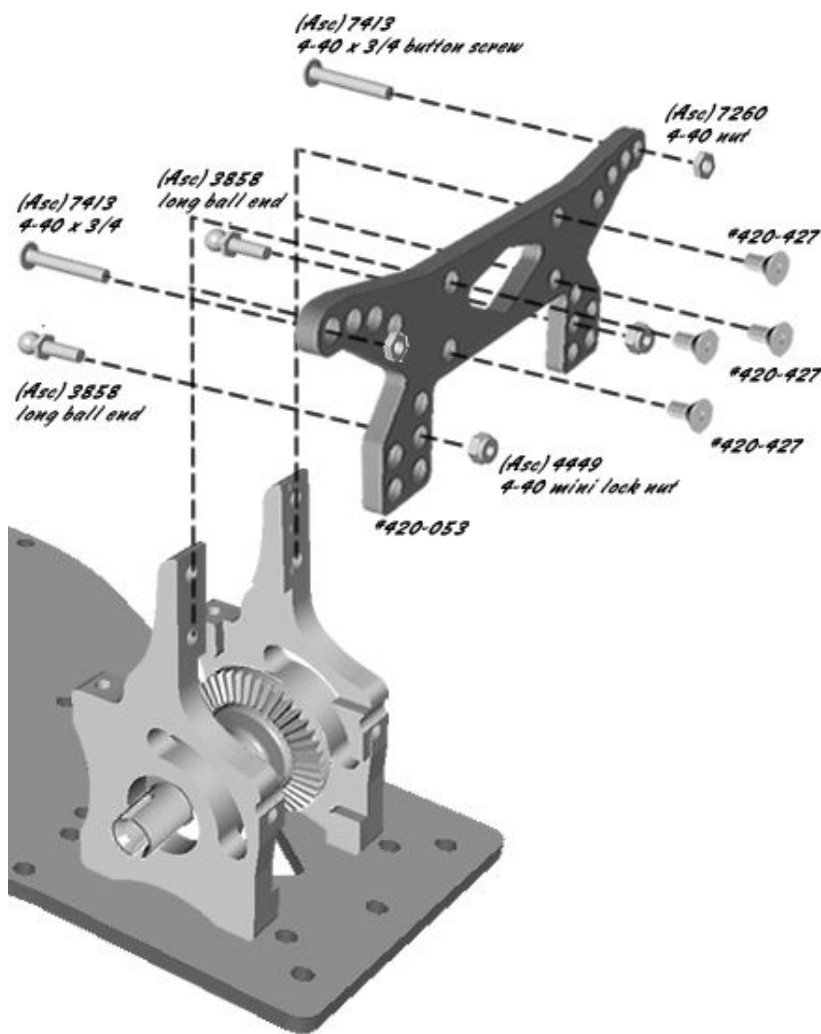

0
 1
 2
 3
 4
 5
 6
 7
 8
 9
 X
 L
 R
 8
 5
 4
 3
 2
 1

1) In this step you will finally be tightening all the screws. The reason behind this chart is so that you will avoid chassis tweak! After some racing and a few hard hits you will always want to check your chassis tweak, just loosen the listed screws and refer to this chart to re-tighten and re-set your tweak. You will want to tighten the screws on the bottom of the chassis first in the correct order and then lay the chassis on a super flat surface and finish tightening the top plate screws in the correct order. **DO NOT USE THREAD LOCK**

Step 9

2) Finish tightening the pin block screws on the bottom of the chassis after you tighten the chassis and top plate screws. Finish tightening the screws on the shock towers in the correct order. **DO NOT USE THREAD LOCK**

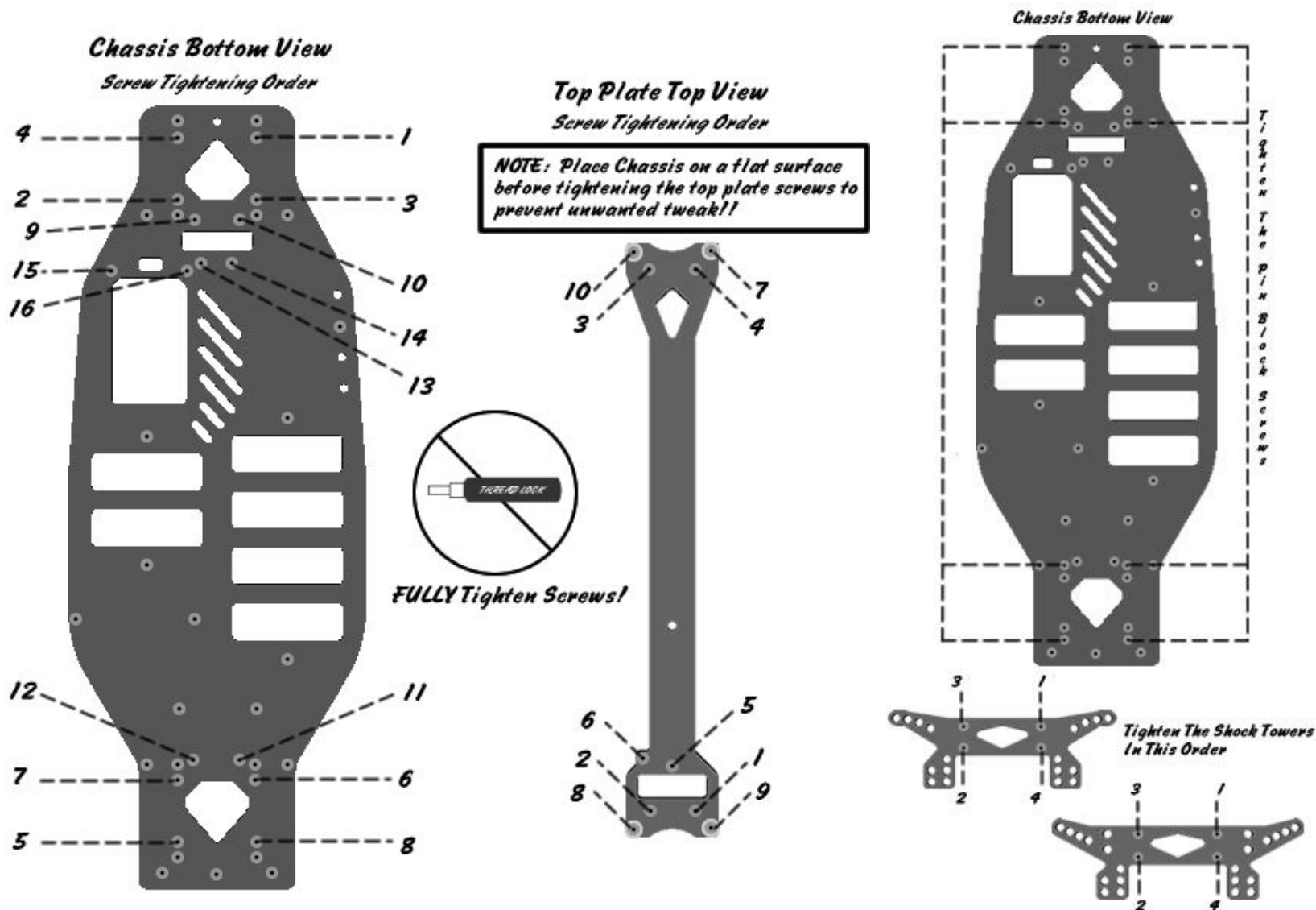

U
S
E
S
U
E
0
0
5
0
X
L
R
8

1) Attach the four aluminum battery brace standoffs (#420-058) to the main chassis using four 4-40 x 1/4 flat head stainless screws (#420-427). Use thread lock.

2) Secure the long battery brace (#420-056) to the aluminum battery brace standoffs using two 4-40 x 1/4 flat head stainless screws (#420-427). Secure the short battery brace (#420-057) to the aluminum standoffs using two 4-40 x 1/4 flat head stainless screws (#420-427). DO NOT USE THREAD LOCK on the top screws.

Page 10

Step 10

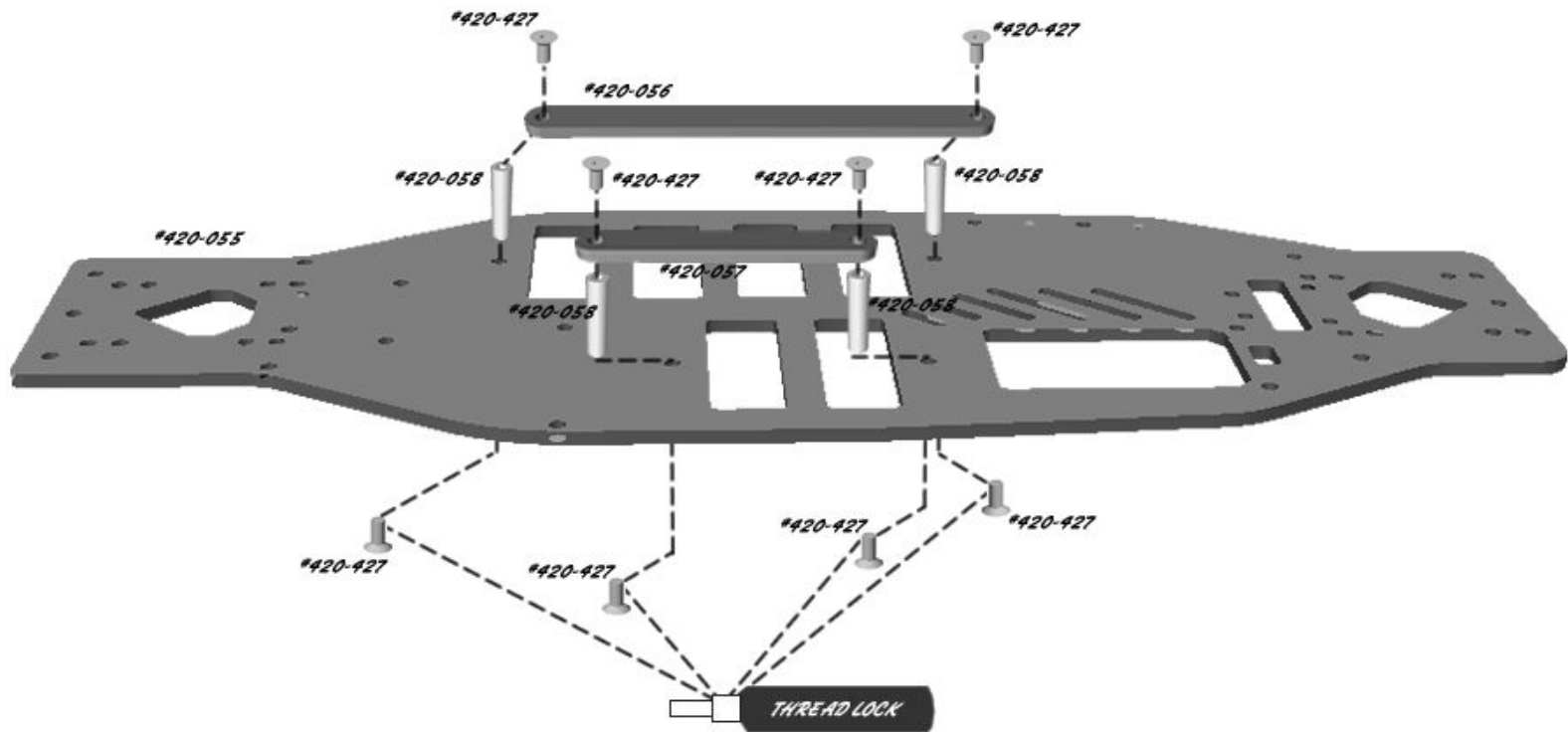



1) Install the milled bumper (#420-023) to the chassis (#420-055) using three 4-40 x 3/8 flat head stainless screws (#420-028), three 4-40 steel washers (#420-438), and three 4-40 lock nuts (#420-442). Make sure these are nice and snug. Install the two Associated front body posts (#8818) using two 4-40 x 1/2 button head stainless screws (#420-432)

2) Attach the two Associated rear body posts (#8874) to the rear shock tower (#420-054) using two 4-40 x 3/8 flat head stainless screws (#420-028). You will want to use a front foam bumper, we recommend the P-Dub racing foam front bumper.

Step 11

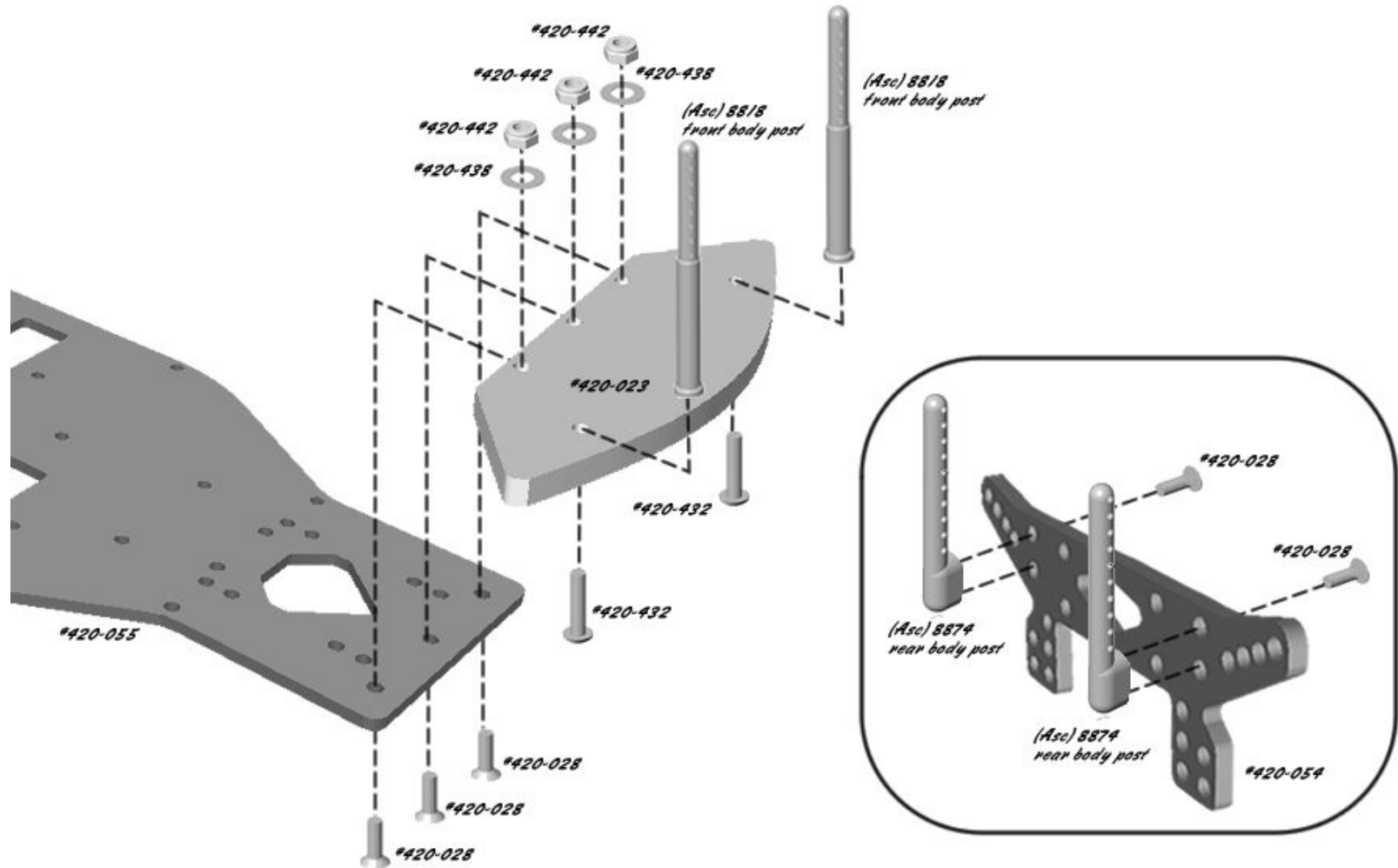



Step 12

1) Attach the rear hub carrier Associated (#3876) or we recommend Losi xxx-s 0 degree (#Losa9847) to the aluminum rear arm (#420-012) using the Associated hinge pin (#3866), and two Associated plastic washers (#4187). Secure with set crew on hub carrier. Attach the wheel hexes. Install the 8-32 set screws (#420-059) to use for droop adjustment. NOTE: When using Losi rear hub carriers you will need to add one small gold shim between the arm and hub carrier as shown.

2) Attach the Associated 4 degree front spindle and block carriers (#3873) or we recommend Losi xxx-s 4 degree front spindles and block carriers (#Losa9757) to the aluminum front arms (#420-011) using the Associated hinge pin (#3866) and securing it with the set screw on the carrier. Attach the wheel hexes. Install the 8-32 set screws (#420-059) to use for droop adjustment. NOTE: Use the 4-40 stainless nut (#420-440) on the steering block to reduce bump steer as shown..

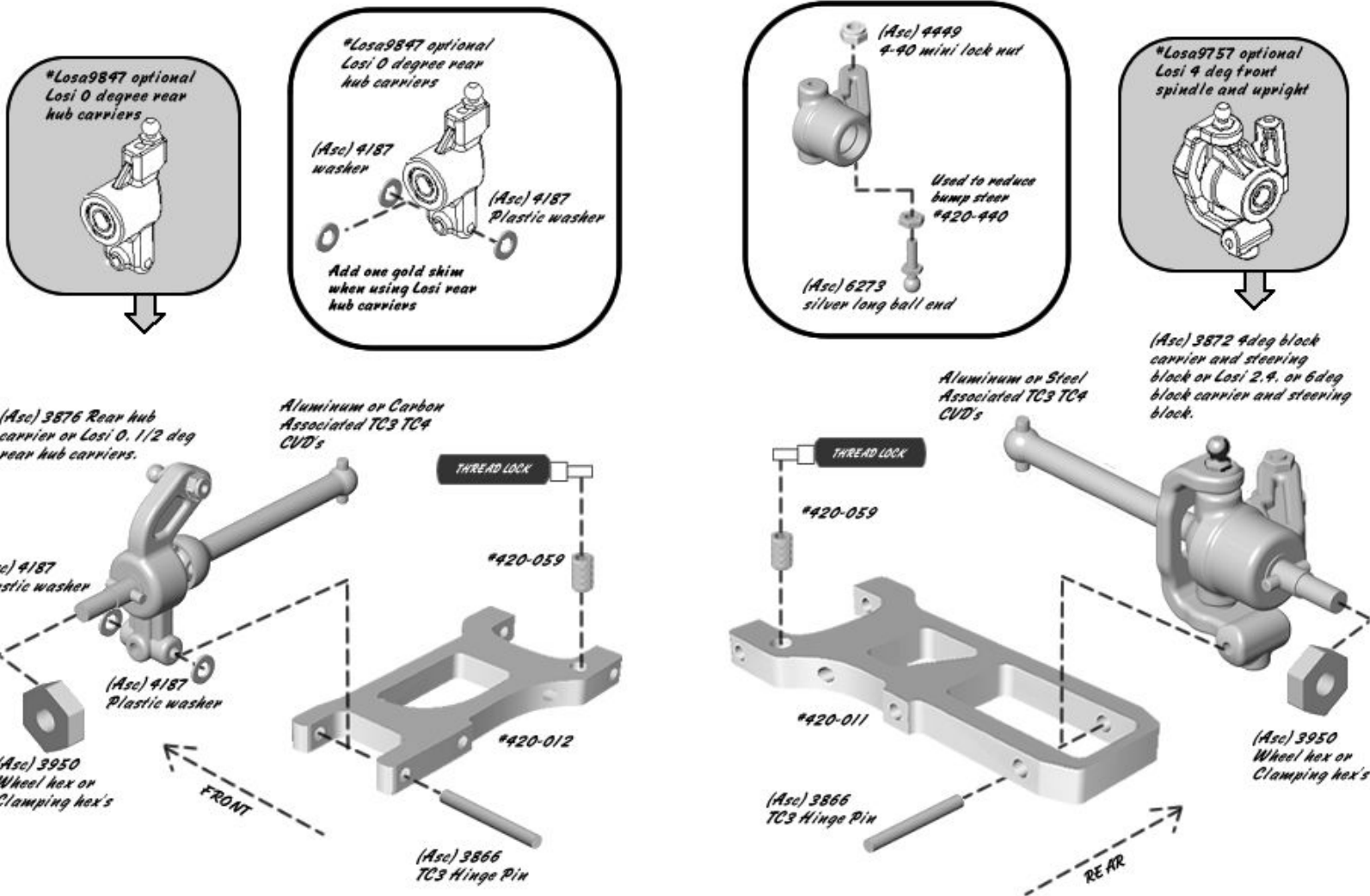



1) Install the four threaded shocks Associated (#3963) or any comparable threaded shocks using one Associated (#6473) shock bushing and one 4-40 lock nut (#420-442) on the tops. Use one 4-40 x 1/2 button head stainless screw (#420-432) on the bottoms of the shocks.

2) Install your servo as shown using the stock Associated servo mounts (#7336) and mounting hardware. You will need to use a Losi servo saver (#Losi1540 & Losi1542) or Kimbrough mid size servo saver. Make sure you set the servo saver offset to about 7.5mm and then adjust your radio and linkage to get proper steering.

Step 13

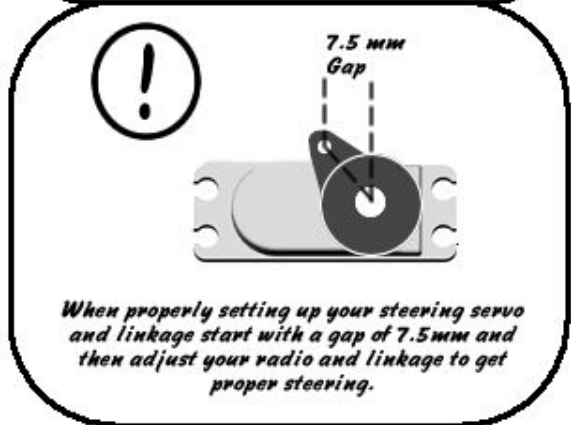
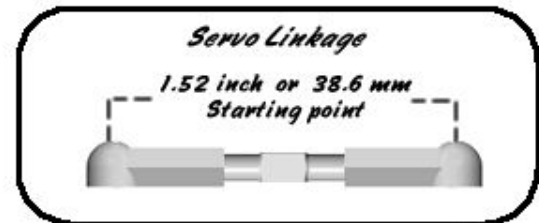
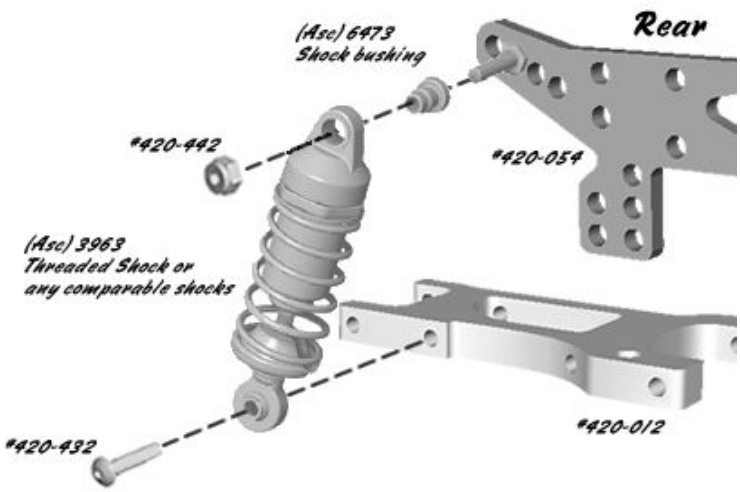
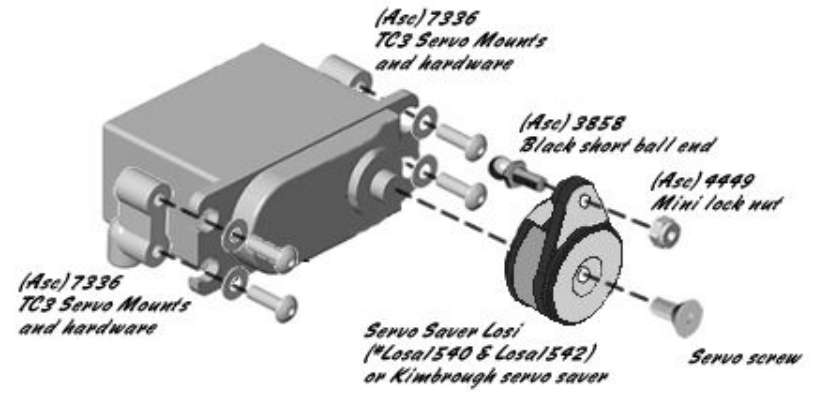
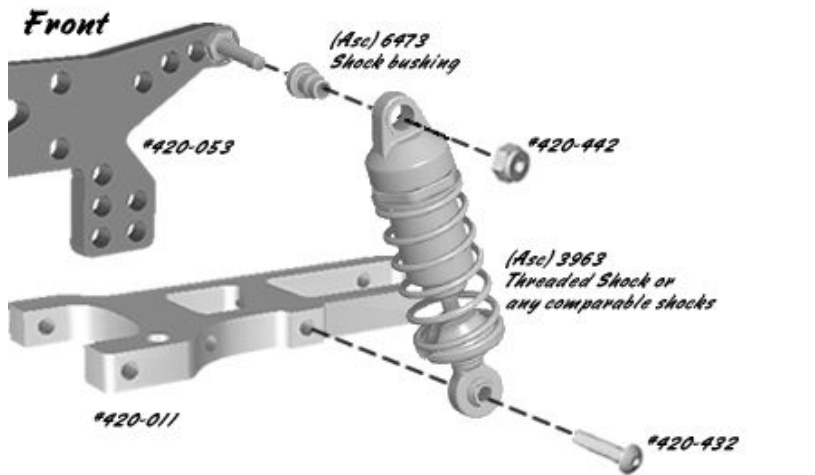

U
S
S
U
E
S
X
L
R
8

1) Install your receiver and speed control as shown.

2) Using the example below, route the servo and personal transponder wire below the drive shaft and on the chassis. You will want to secure it with double sided tape or small wire holds if possible (sold at radio shack and other small electronics stores).





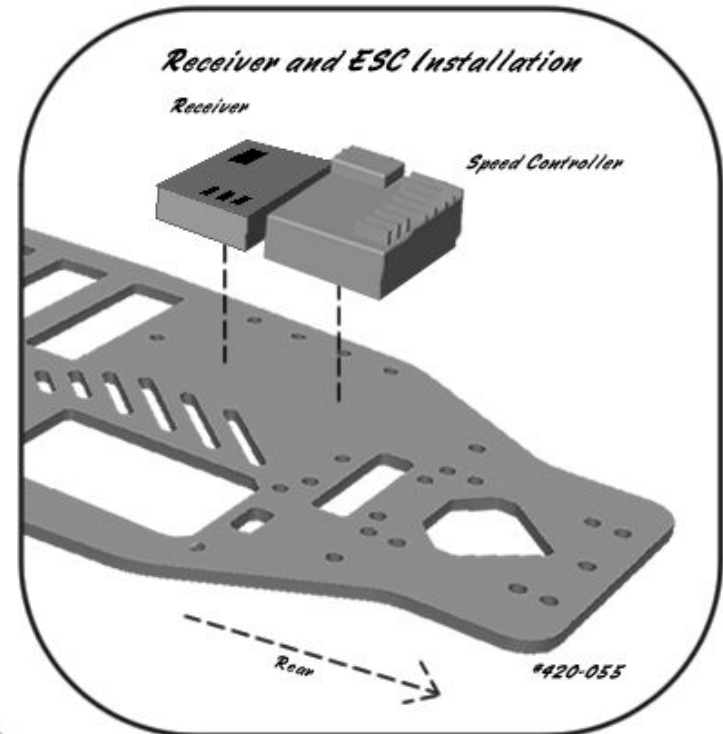
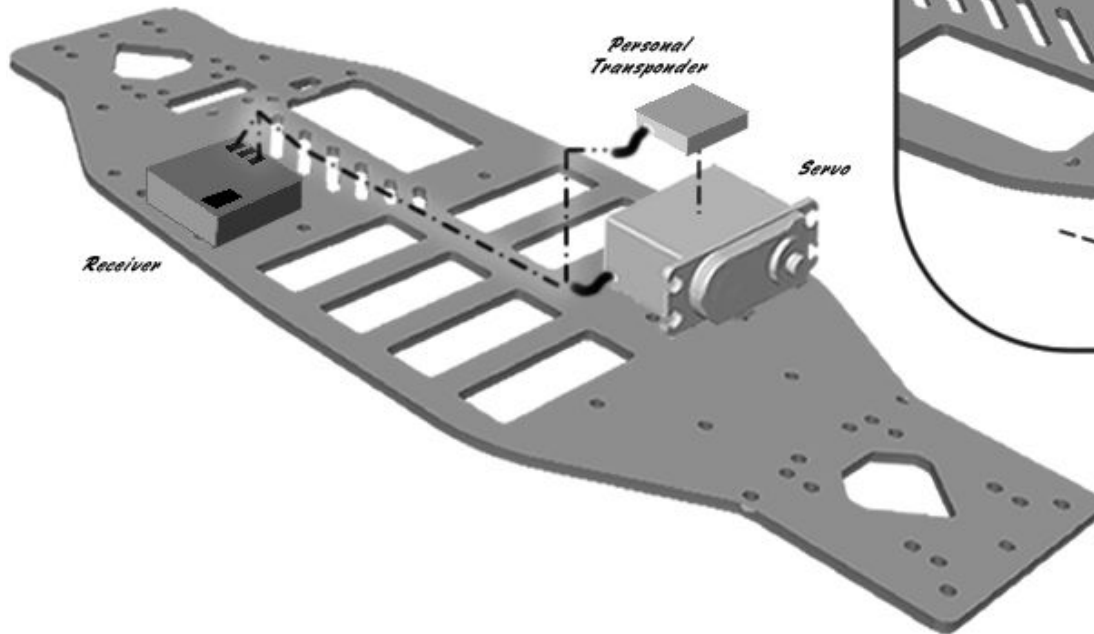

















**Wire Routing Example
(Servo, and Transponder wire)**

Route the servo and personal transponder wires as shown (underneath the drive shaft). Use double sided tape or wire holds if possible.





XLR8 Hardware List

50*	<p>*420-427</p>  <p>4-40 x 1/4 Flat Head</p>	<p>*420-028</p>  <p>4-40 x 3/8 Flat Head</p>	<p>*420-030</p>  <p>3mm x 8mm Flat Head</p>	<p>*420-031</p>  <p>3mm x 20mm Flat Head</p>	<p>*420-430</p>  <p>4-40 x 3/16 Button Head</p>	<p>*420-431</p>  <p>4-40 x 1/4 Button Head</p>
6*	<p>*420-432</p>  <p>4-40 x 1/2 Button Head</p>	<p>*420-059</p>  <p>8-32 Set Screw</p>	<p>*420-032</p>  <p>Countersunk Washers</p>	<p>*420-038</p>  <p>4-40 Washer</p>	<p>*420-037</p>  <p>3mm Washer</p>	<p>*420-036</p>  <p>Differential shim .016</p>
2*	<p>*420-440</p>  <p>4-40 Hex Nut</p>	<p>*420-442</p>  <p>4-40 Hex Lock Nut</p>	<p>*420-039</p>  <p>3mm Hex Nut</p>	<p>*420-041</p>  <p>3mm Hex Lock Nut</p>	<p>*420-062</p>  <p>Brass washers</p>	<p>*420-435</p>  <p>.062 Plastic Washer</p>
8*	<p>*420-026</p>  <p>Brass swivel bushing</p>	<p>*420-024</p>  <p>Brass steering bushing</p>	<p>*420-058</p>  <p>Battery Brace Standoff</p>	<p>*420-061</p>  <p>Small Pin</p>	<p>*420-060</p>  <p>Optional solid pin bushings</p>	



XLR8 Parts List

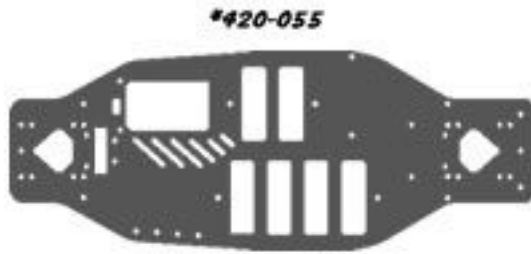

3mm Carbon Fibre Chassis

1*



3mm Carbon Fibre Front Shock Tower

1*



3mm Carbon Fibre Rear Shock Tower

1*



3mm Carbon Fibre Top Plate

1*



3mm Carbon Fibre Long Battery Brace

1*



3mm Carbon Fibre Short Battery Brace

1*



Milled Poly Pro Plastic Bumper

1*



Aluminum Front/Rear Left & Right Differential Housings

2 sets*



Aluminum Steering Rack

1*



***420-016**



Aluminum Solid One Piece Drive Shaft

1*

***420-018**



Aluminum Gear Adapter

1*

***420-011**



Aluminum Front Arms

2*

***420-012**



Aluminum Rear Arms

2*

***420-010**



Aluminum Motor Mount/Heat Sink

1*

***420-014**



Aluminum Front/Rear Shaft Supports

2*

***420-015**



Aluminum Front/Rear Middle Shaft Supports

1*

***420-019**



Aluminum Left/Right Inner Pin Blocks

2 sets*

***420-020**



Aluminum 0 degree Solid Outer Pin Block (shortest)

1*

***420-021**



Aluminum 1 degree Solid Outer Pin Block (mid length)

1*

***420-022**



Aluminum 1 degree Solid Outer Pin Block (longest)

1*

Associated Parts Reference

Team Associated Hardware Parts Used

- | | | | |
|------------|--------------------------|-------------|-----------------------|
| 1) ASC3858 | Short black ball ends | 10) ASC3914 | Drive pinions |
| 2) ASC3858 | Long black ball ends | 11) ASC3919 | Dowel pin |
| 3) ASC6917 | 4-40 x 3/8 button screws | 12) ASC3919 | Large E clip |
| 4) ASC7337 | 4-40 steel washers | 13) ASC3911 | Differential shims |
| 5) ASC7413 | 4-40 x 3/4 button screws | 14) ASC3911 | Input shaft shims |
| 6) ASC7260 | 4-40 mini hex nuts | 15) ASC6473 | Shock bushings |
| 7) ASC4449 | 4-40 mini lock nuts | 16) ASC6273 | Long silver ball ends |
| 8) ASC6288 | 4-40 x 1/4 button screws | 17) ASC3960 | Sway bar kit |
| 9) ASC3866 | TC3 hinge pin set | | |

Team Associated Component Parts Used

- | | | | |
|---------------|--|---------------|----------------------|
| 1) Associated | CVD's aluminum, carbon can be used in the rear | 9) ASC8874 | Rear body posts |
| 2) Associated | Aluminum wheel hexes (clamping recommended) | 10) ASC8818 | Front body posts |
| 3) Associated | TC3-TC4 Bearing set | 11) Kimbrough | Mid-size servo saver |
| 4) Associated | Turnbuckle set (titanium recommended) | | |
| 5) Associated | Threaded shock set (or any comparable set) | | |
| 6) Associated | TC3 Front steering blocks and block carriers (Losi xxx-s 4 degree recommended) | | |
| 7) Associated | TC3 Rear hub carrier (Losi xxx-s 0 degree recommended) | | |
| 8) Associated | TC3-TC4 Differentials F/R (Aluminum recommended) | | |
- LOSI**
- | | |
|------------------------|--|
| 1) LOSA1540 & LOSA1542 | Servo saver and hardware (recommended) |
| 2) LOSA9757 | Optional 4 degree front steering blocks and block carriers (recommended) |
| 3) LOSA9847 | Optional 0 degree rear hub carriers (recommended) |

